Development for Renewable Energy Applications
Mainstreaming and Market Sustainability (DREAMS)
Project...

(a short story on how energy dreams may come true)



Solar PV Irrigation System: (Component of a Smart Grid Household Electrification Project under the Local RE Plan of the DREAMS Project)

Sitio Bubusawin, Barangay Apurawan,
Aborlan Palawan

Local Partners

- Palawan Electric Cooperative
- Local Government of Aborlan, Palawan
- Apurawan Farmers Association



What is the Local RE Planning (LREP) Process

- ❖ Build local capacities and experience-based knowledge in planning and utilization of RE Sources
- ❖ Integrate RE policies and projects in Executive and Legislative agenda and investment plans
- ❖ Local initiatives to support the National RE Program 2020-2040
- ❖ Establish a Support Facility for RE (SF4RE) to invest in local RE initiatives — **like Solar PVs for Irrigation**



Components of the Smart Grid Household Electrification Project

A. Household Electrification

- * 19.4kwp
- * 120 out of 297 households to be served
- * From 4-5 hours to 24/7 electricity supply

- * Pre-paid metering system

- * Bundle of household services and appliances:
 - 200 Wh/day (power phone charger, lights, fan);
 - 380 Wh/day (power phone charger, lights, fan, TV);
 - 800 Wh/day (power phone charger, lights, fan, TV, refrigerator);
 - 1,200 Wh/day (freezer);
 - 1,600 Wh/day (power phone charger, lights, fan, TV, freezer)

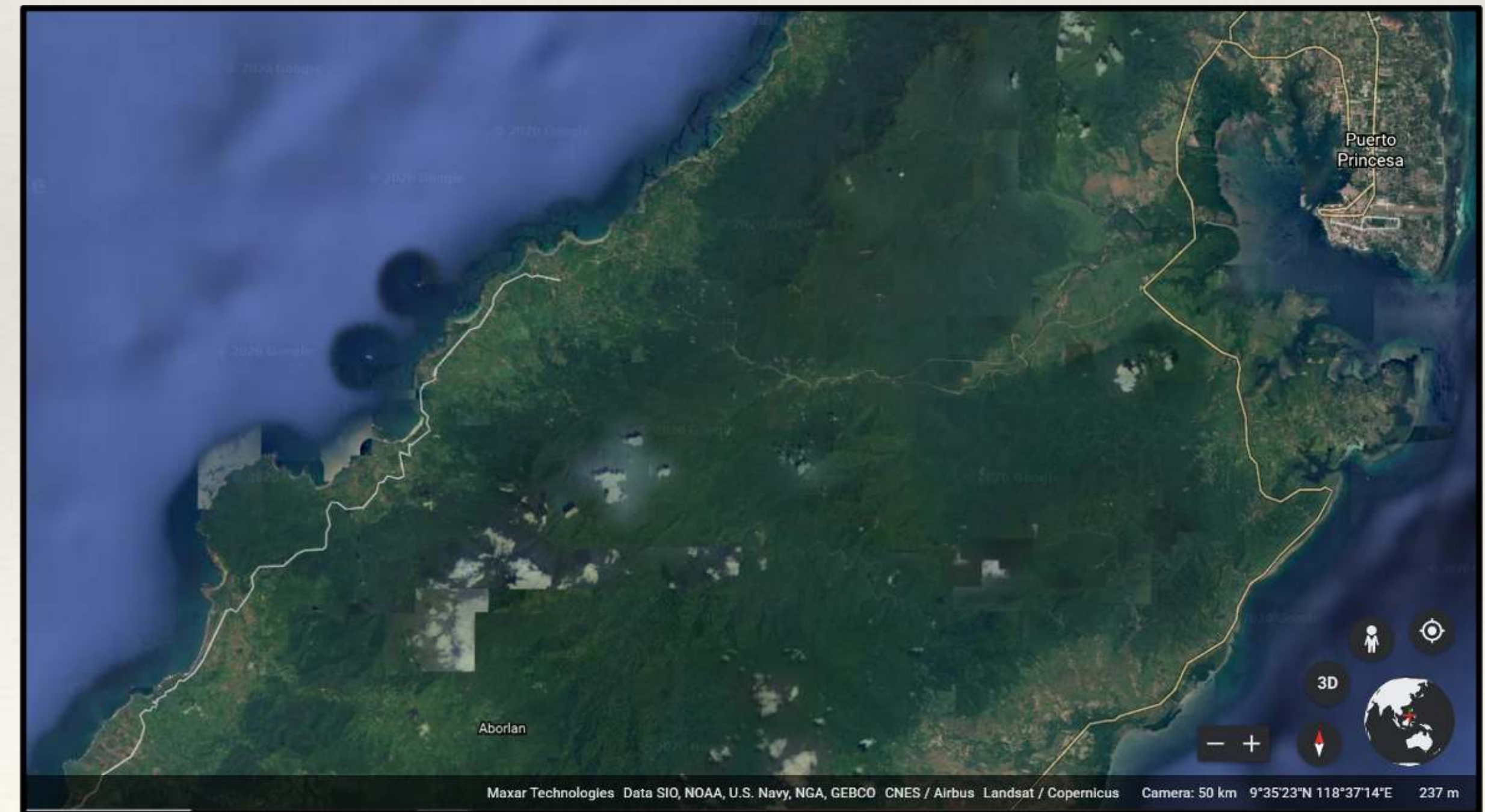

B. Solar PV Irrigation Component

100 farming households

- 3.6kW PV powering a 1.4kW pump (roughly 2 Hp)
- Ave production of 102 m³ per day, (approx 20.4 m³ per hour, 5 hours sunshine hours)
- submersible solar powered pump (may be movable or stationary)
- still need to set performance standards based on actual operation for cost-benefit investment models
- maintenance cost and tariff for discussion by PALECO and Farmers Association

Cost Breakdown

Materials= PhP 605,000.00
Management and logistics = 440,000.00

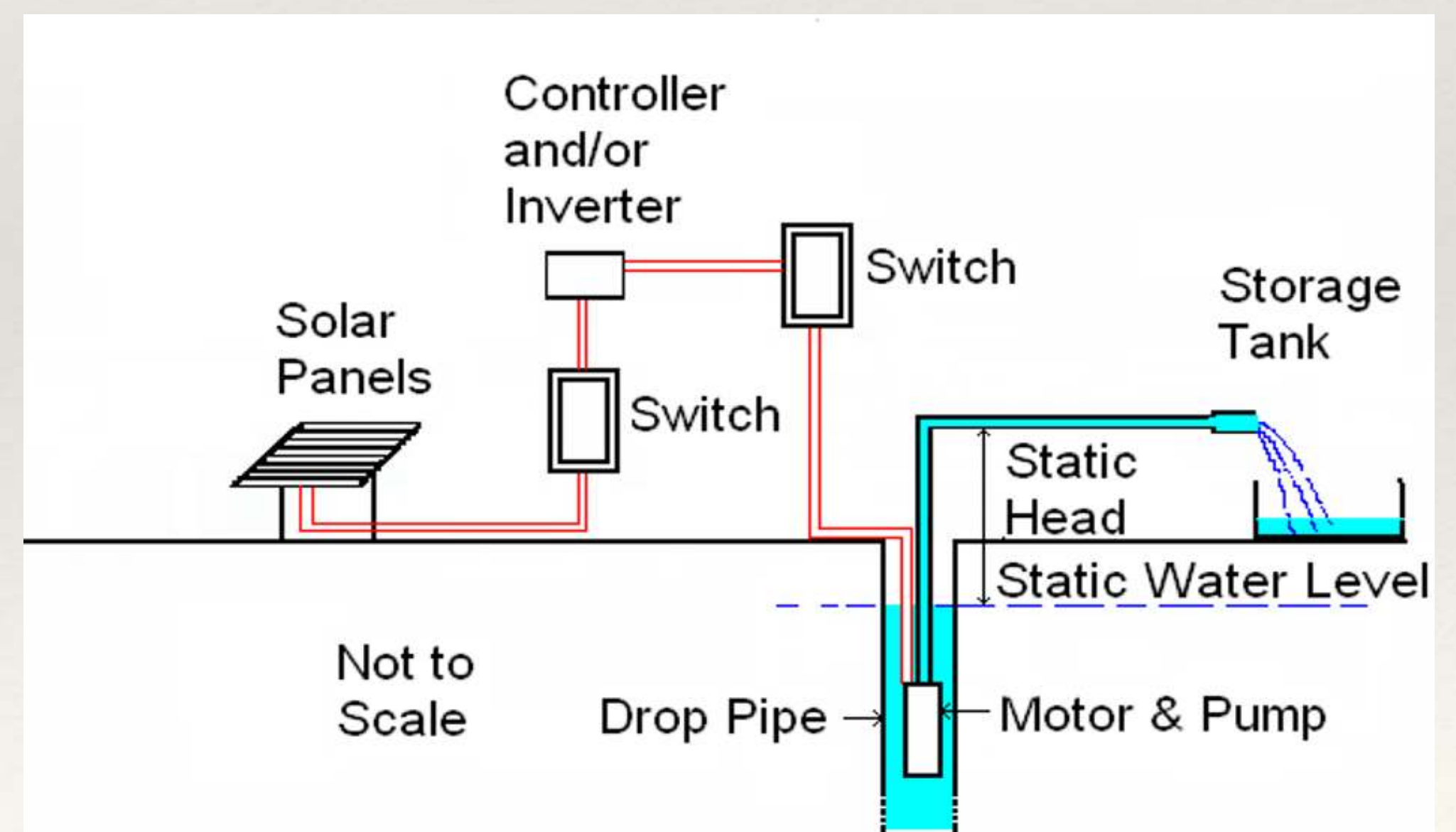

“DREAMS Come True” : Support Facility for RE (SF4RE)

Solar PV powered Bioethanol Distiller, Aparri Cagayan 36kW, 3 barangays

HH Smart Grid System, Island brgys of Burdeous, Quezon, 42kW 250 hh

Mindoro (Household Electrification/PURE)

DC Smart Grid for HH Electrification and Solar PV Irrigation, Aborlan, Palawan, 29kW, 121 hh,

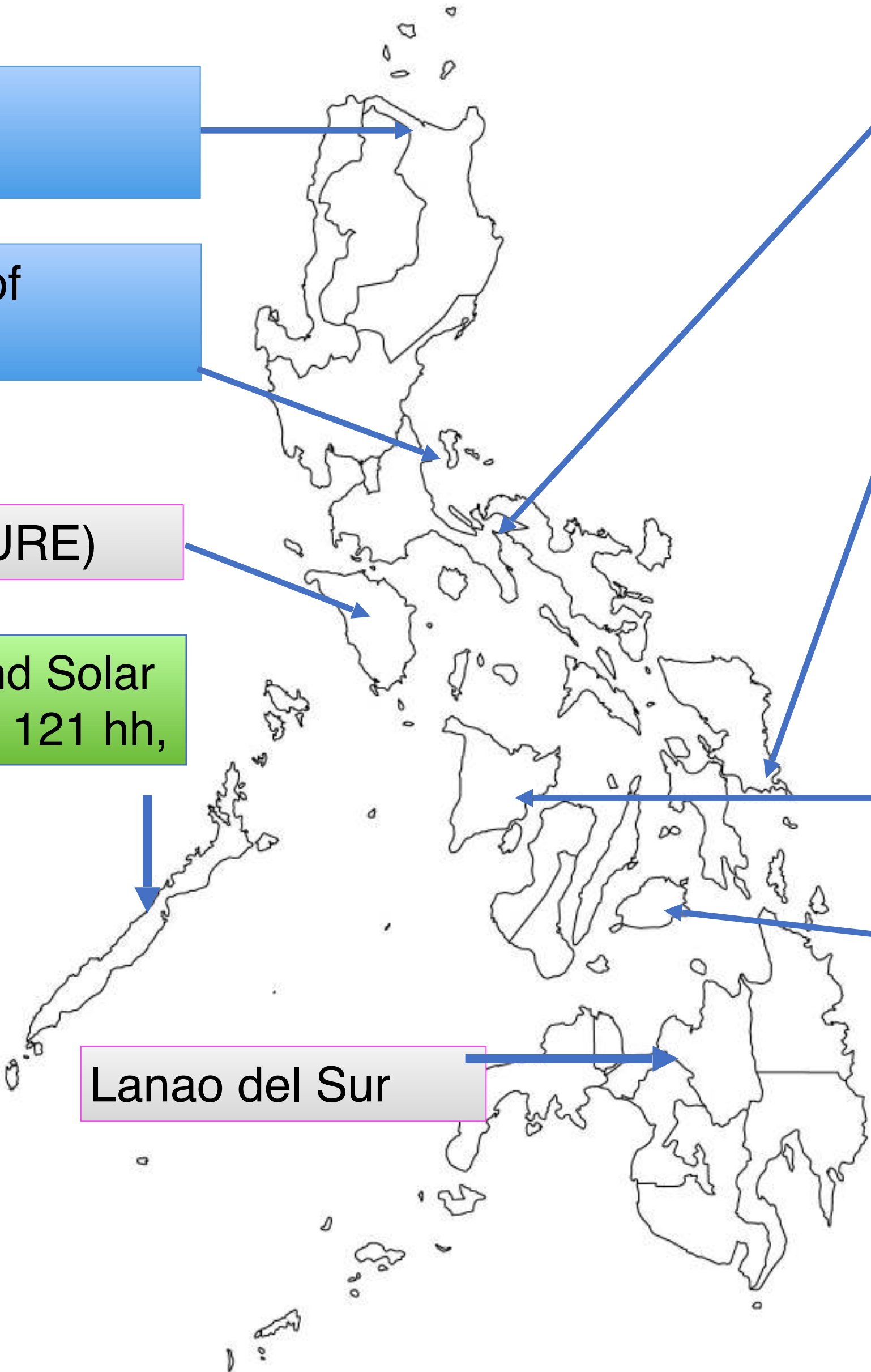

Solar PV Powered Potable Water System, Goa Camarines Sur, 30kW, 824HH

Mini-Hyro Rehabilitation, Lawaan, East Samar, 1MW, 11,000+ HH

Solar PV Rooftop on key offices in LGU Compound of Concepcion, Iloilo, 80kW, 521HH

Solar PV Rooftop, Provincial Hospital of Iloilo, 75kW

MicroHydro Plant Rehabilitation, Ajuy Iloilo, 45kW, 9,920hh

Expansion of Pamilacan Island, Baclayon Community Solar PV Mini-grid, Bohol, 40kW, 357HH

Lanao del Sur

On-going

bidding stage

for approval

for study/design



Trending Results:

Productive Use of RE &
Basic Services

Modest Local Investments

Green Jobs

Energy-filled Community
Participation



Development for Renewable Energy Applications Mainstreaming and Market Sustainability (DREAMS) Project..

(wait for the next chapter please)



REMB is the implementing unit
of the DREAMS project

Solar PV Irrigation System:
**(Component of a Smart Grid Household
Electrification Project under the Local RE Plan)**

**Sitio Bubusawin, Barangay Apurawan,
Aborlan Palawan**

Local Partners

- **Palawan Electric Cooperative**
 - **Local Government of Aborlan, Palawan**
-